

## GAS P350-450-550/MCE-LX-EL EVO

Burners for gas with electronic control box. Two stages progressive or modulating operation (if equipped with addition of optional modulation kit PID and probe; to guarantee an ideal proportionality of the power supplied to the thermal load).

Composed by: fan at high pressurisation at reverse blades, additional large diameter flange on the fan motor for easy extraction of the motor group + fan and combustion head with adjustment at high efficiency and high flame stability. Compact overall dimensions and disposition rationalized of the components with accessibility facilitated for operations of setting and maintenance.

Equipped as standard with UV probe and pilot flame.

Gas train completely assembled and tested; complete of: working valve class A - safety valve class A - minimum gas pressure switch - gas valve proving pressure switch - filter.

Complete of flange and gasket for installation on generator.

The servomotors are independent and managed directly from the electronic control box of the burner: one servomotor for the gas modulator and one servomotor for the air shutter.

The burners are equipped with a display that allows to:

- adjust the operating parameters of the burner
- visualize the flame intensity
- adjust the operating curve of the burner (air / gas ratio)

With the addition of optional accessories (probes) thanks to the most advanced systems for automatic modulation in mechanical or electronic version, the burner constantly ensures the proper gas / air ratio. The maximum efficiency of the returns in each combustion point derived from the punctual adaptation of the thermal load to the heat requirements of the burner at any instant of operation.

In the version with the electronic cam the fuel / combustion air curve, more extended, is fully exploited, guaranteeing excellent performance in terms of accuracy and speed, even during the calibration phase.

A microprocessor monitors the different stages of the process and allows the correct repetition of the sequences of operation.

Optional accessories: PID power modulator kit, probe, PC interface, VSD, O<sub>2</sub> control, O<sub>2</sub> + CO control, field bus (profibus, modbus, profinet).

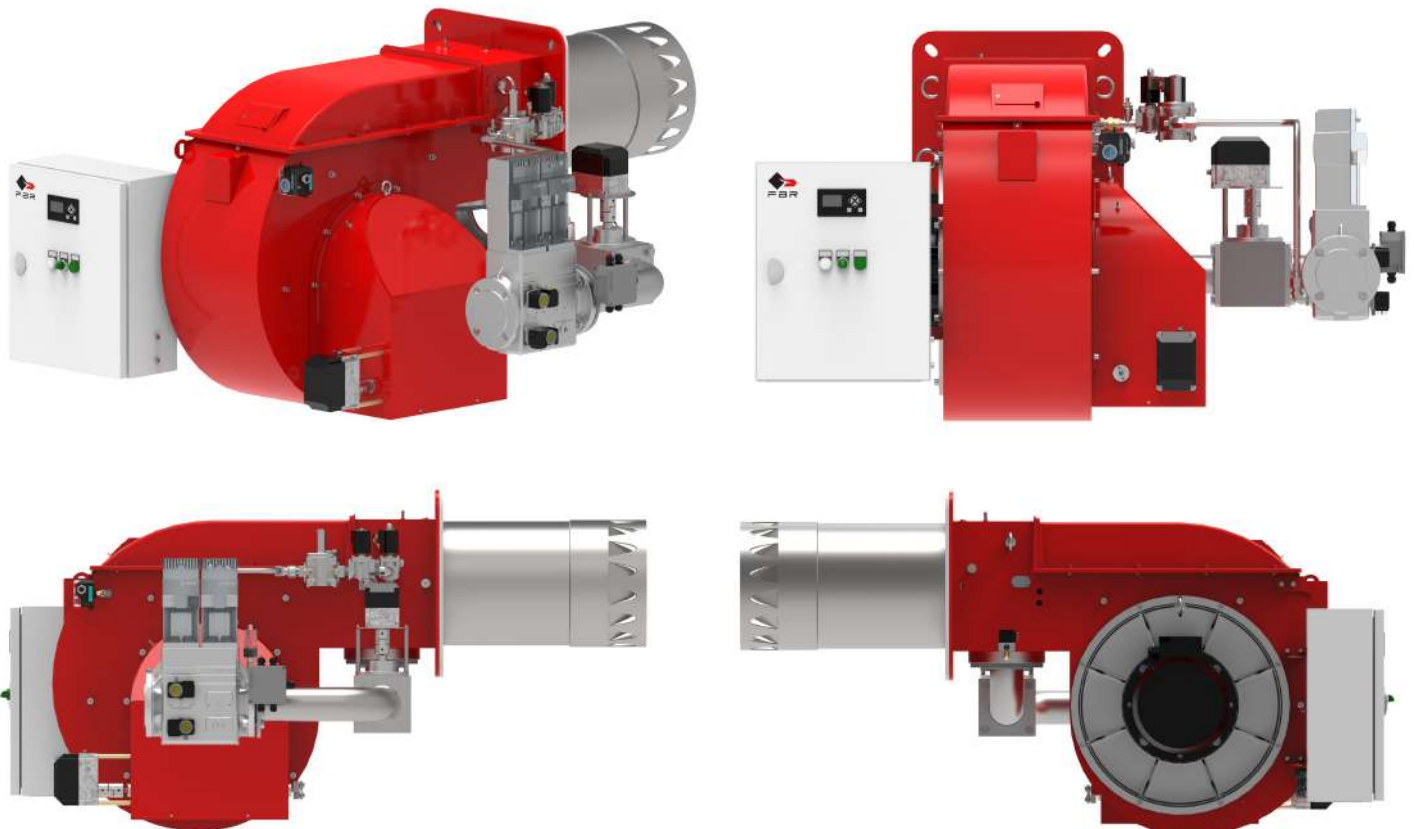

CONTROL BOX LAMTEC BT3

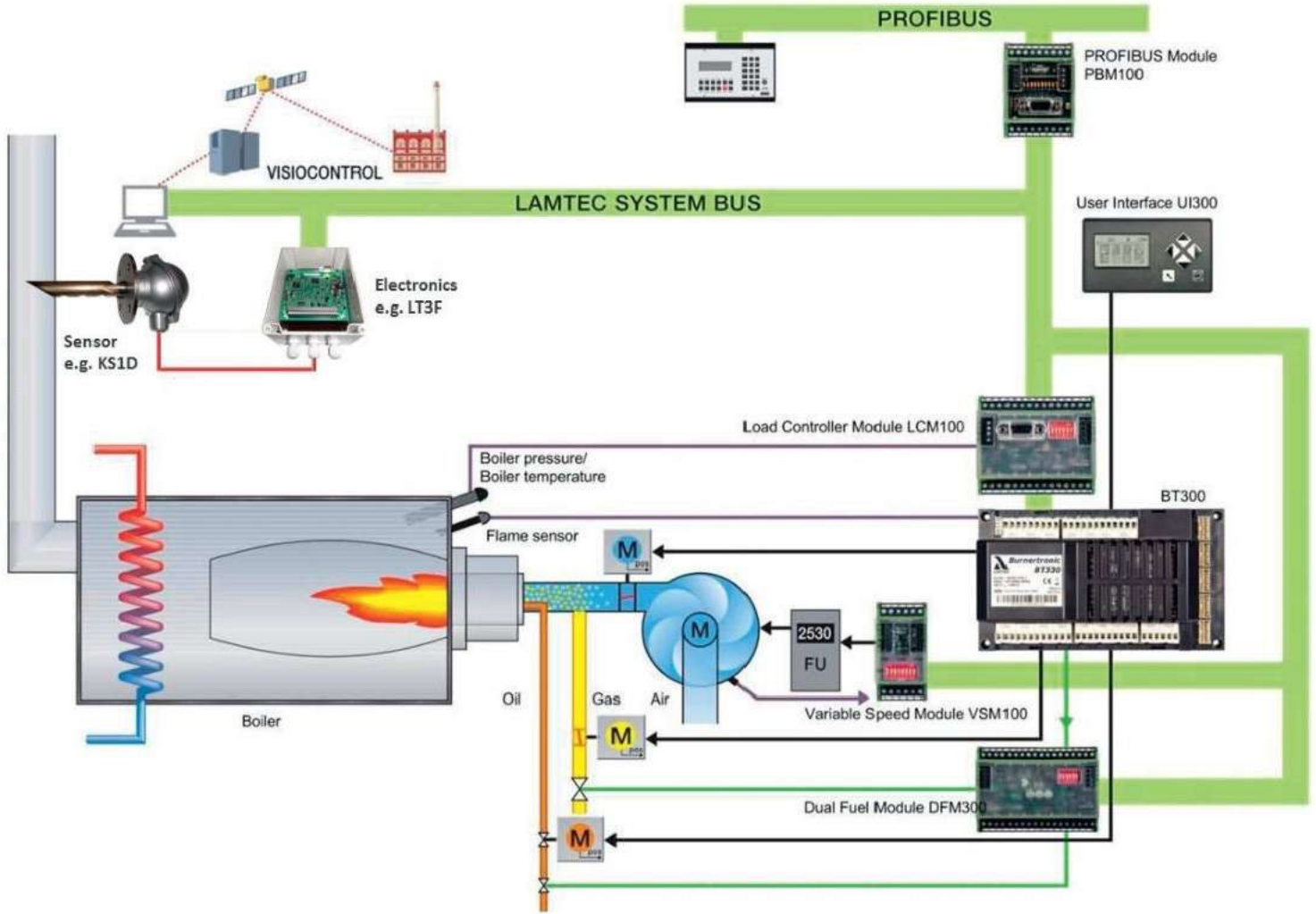

Fig. 1 Control box Lamtec BT3

**TECHNICAL DATA GAS P350/MCE-LX-EL EVO - GAS P450/MCE-LX-EL EVO - GAS P550/MCE-LX-EL EVO**

MODEL		GAS P350/MCE -LX-EL EVO	GAS P450/MCE -LX-EL EVO	GAS P550/MCE -LX-EL EVO
Thermal power min. 1°st. / min. 2°st. - max. 2°st. *	[Mcal/h]	583/1200-3500	750/1600-4500	916/2000-5500
Thermal power min. 1°st. / min. 2°st. - max. 2°st. *	[kW]	678/1395-4070	872/1860-5232	1065/2325-6395
Gas flow G20 (NATURAL GAS) min. 1°st. / min. 2°st. - max. 2°st. *	[Nm³/h]	68/140-409	88/187-526	107/234-642
<b>Fuel: NATURAL GAS (second family)</b>				
Fuel category:		I2R,I2H,I2L,I2E,I2E+,I2Er,I2ELL,I2E(R)		
NOx **	[mg/kWh]	< 80: class 3 (EN 676)		
<b>Intermittent working operation (min. 1 stop every 24 hours) two stages progressive or modulating</b>				
Environmental conditions operation / storage:		-15...+40°C / -20...+70°C, rel. humidity max. 80%		
Max. temperature combustion air	[°C]	60	60	60
Minimum pressure gas train D2"-S-F50 NATURAL GAS ***	[mbar]	188	319	490
Minimum pressure gas train DN65-S-F65 NATURAL GAS ***	[mbar]	55	98	161
Minimum pressure gas train DN80-S-F80 NATURAL GAS ***	[mbar]	42	77	130
Minimum pressure gas train DN100-S-F100 NATURAL GAS ***	[mbar]	32	60	104
Maximum pressure at the entry of valves (Pe. max)	[mbar]	500	500	500
Nominal electric power	[kW]	9.4	11.2	15.2
Fan motor	[kW]	9.2	11	15
Nominal motor current absorption	[A]	18.5	24	32
Nominal auxiliary absorption	[A]	0.6	0.6	0.6
Power supply:		3~400V, 1N~230V - 50Hz		
Electric protection degree		IP40	IP40	IP40
Noisiness **** min. - max.	[dB(A)]	84-85	85-85	86-89
Burner weight	[kg]	205	250	-

\* Reference conditions: Environment temperature 20°C - Barometric pressure 1013 mbars - Altitude 0 metre (sea level).

\*\* To obtain this low Nox emission like in the declaration, it's necessary to couple the burner to the proper boiler for this application: boilers with 3 turns for the exhaust gas, condensing boilers and any generator with direct exhaust outlet and the thermal load isn't higher than 1,1 MW/m³.

\*\*\* Minimal feeding-gas pressure to the gas train to get the maximum power of the burner, considering counter-pressure in combustion chamber of value 0 (zero).

\*\*\*\* Measured sonorous pressure in the laboratory combustion, with functional burner on beta boiler to 1 metre of distance (UNI EN ISO 3746 - Control method Class 3 - The tolerance on the measured sound pressure can be assumed equal to ± 1 [dB (A)]).

**OPERATING RANGE DIAGRAM GAS P350/MCE-LX-EL EVO - GAS P450/MCE-LX-EL EVO - GAS P550/MCE-LX-EL EVO**

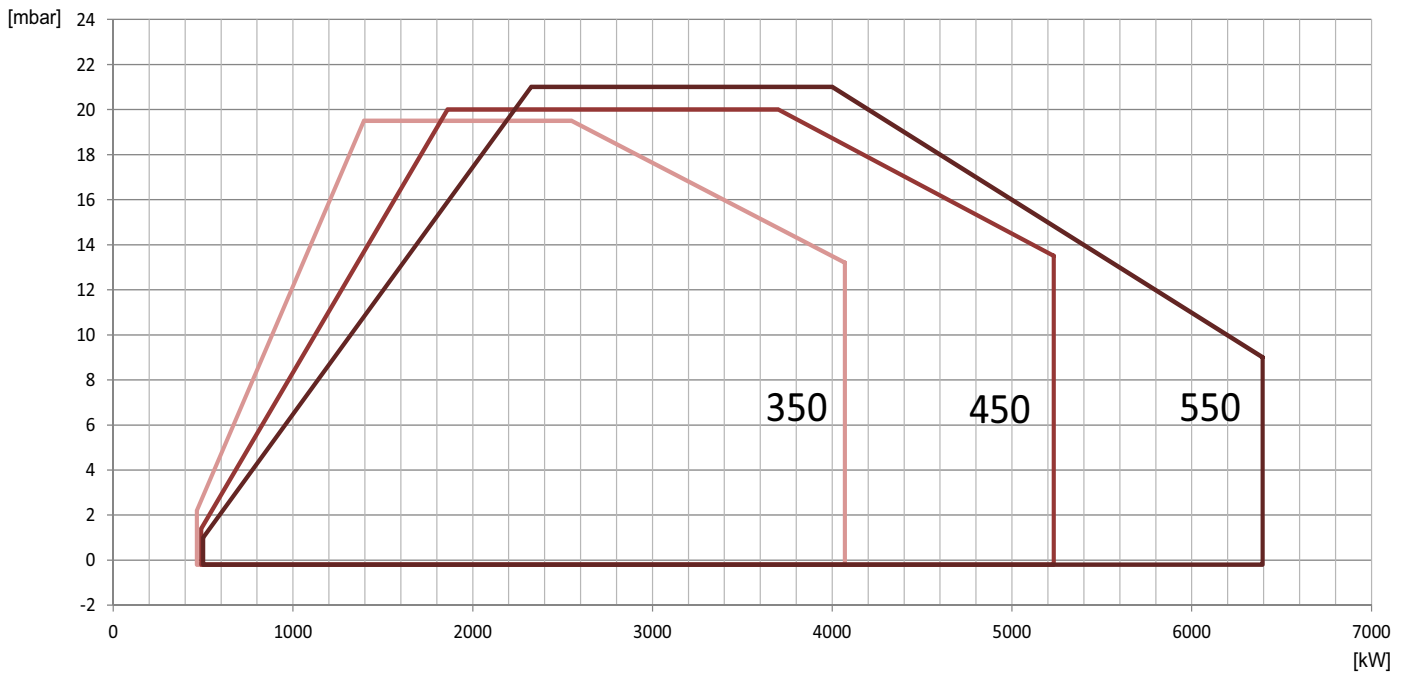

**Fig. 2** X = Thermal power [kW] Y = Pression in the combustion chamber [mbar]

The firing rates has been obtained based on test boilers in accordance with EN676 standards and are indicative of matching the burner to the boiler. For the correct operation of the burner bruciatore, combustion chamber dimensions must be in accordance with current regulation. In case of non-compliance, contact the manufacturer.

**DIMENSIONS [MM]**

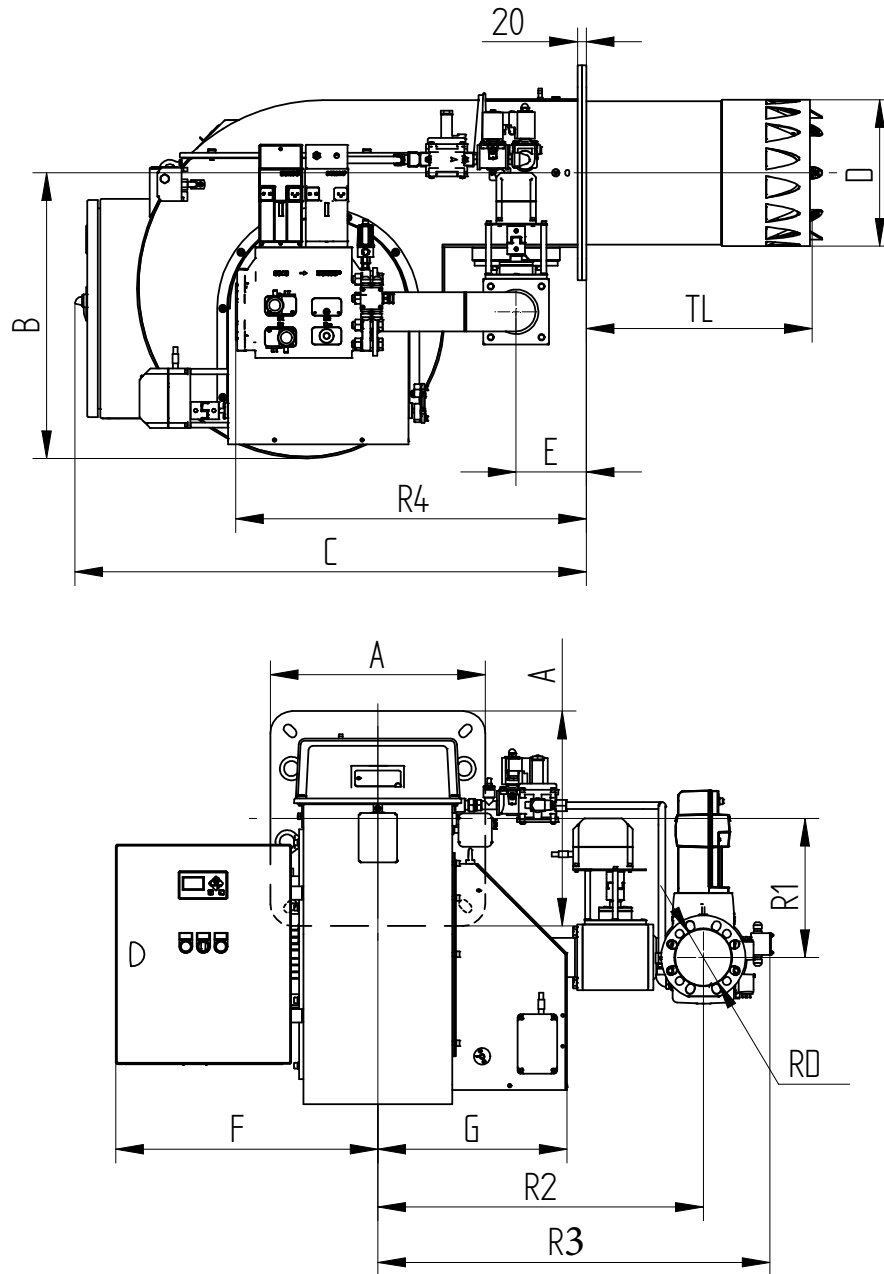

**Fig. 3** Dimensions

MODEL	A	B	C	D	E	F	G	R1	R2	R3	R4	RD	Gas train weight
GAS P350/MCE-LX-EL EVO-D2"-S-F50	490	650	1167	334	159	595	425	316	720	840	745	Rp 2"	17 kg
GAS P350/MCE-LX-EL EVO-DN65-S-F65	490	650	1167	334	159	595	425	316	745	850	780	DN65	28 kg
GAS P350/MCE-LX-EL EVO-DN80-S-F80	490	650	1167	334	159	595	425	316	745	895	800	DN80	28.5 kg
GAS P350/MCE-LX-EL EVO-DN100-S-F100	490	650	1167	334	159	595	425	316	795	960	840	DN100	-
GAS P450/MCE-LX-EL EVO-D2"-S-F50	490	650	1167	380	159	595	425	316	720	840	745	Rp 2"	17 kg
GAS P450/MCE-LX-EL EVO-DN65-S-F65	490	650	1167	380	159	595	425	316	745	850	780	DN65	28 kg
GAS P450/MCE-LX-EL EVO-DN80-S-F80	490	650	1167	380	159	595	425	316	745	895	800	DN80	28.5 kg
GAS P450/MCE-LX-EL EVO-DN100-S-F100	490	650	1167	380	159	595	425	316	795	960	840	DN100	-
GAS P550/MCE-LX-EL EVO-D2"-S-F50	490	650	1167	380	159	595	425	316	720	840	745	Rp 2"	17 kg
GAS P550/MCE-LX-EL EVO-DN65-S-F65	490	650	1167	380	159	595	425	316	745	850	780	DN65	28 kg
GAS P550/MCE-LX-EL EVO-DN80-S-F80	490	650	1167	380	159	595	425	316	745	895	800	DN80	28.5 kg
GAS P550/MCE-LX-EL EVO-DN100-S-F100	490	650	1167	380	159	595	425	316	795	960	840	DN100	-

**BOILER PLATE**

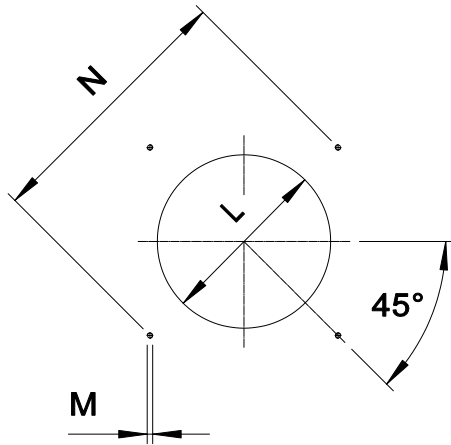

The dimensions of the boiler plate must be as indicated in the drawing.

\* Suggested dimension of connection between burner and generator.

MODEL		L min	L *	L max	M	N min	N *	N max
GAS P350/MCE-LX-EL EVO	mm	350	360	450	M14	552	552	580
GAS P450/MCE-LX-EL EVO	mm	390	400	450	M14	552	552	580
GAS P550/MCE-LX-EL EVO	mm	410	420	450	M14	552	552	580

**FLAME TUBE LENGTH**

Flame tube length must be selected based on the specifications supplied by boiler manufacturer and, in any case, it must be greater than the thickness of the boiler door included its insulation.

In case of boilers with flame inversion or front flue combustion chambers, it is necessary to insulate the area between the flame tube and front door with refractory material. This protection material must not impede flame tube extraction.

MODEL		TL**
GAS P350/MCE-LX-EL EVO	mm	535
GAS P450/MCE-LX-EL EVO	mm	560
GAS P550/MCE-LX-EL EVO	mm	560

\*\* For different flame lengths, please contact our Technical-Sales Department.

## PRODUCT SPECIFICATION

### SHORT DESCRIPTION

Burners for gas two stages progressive or modulating (PID fully modulating) if equipped with addition of optional modulation kit and probe low emissions in conformity with CE 676 class 3 (NO<sub>x</sub> < 80 mg/kWh).

### DETAILED SPECIFICATION

Burner for gas two stages progressive or modulating (PID fully modulating) if equipped with addition of optional modulation kit and probe; low emissions in conformity with CE 676 class 3 (NO<sub>x</sub> < 80 mg/kWh), composed by:

- Fan at high pressurisation at reverse blades;
- Additional large diameter flange on the fan motor for easy extraction of the motor group + fan;
- Combustion head with adjustment at high performance and elevated flame stability equipped with steel blast tube and steel flame disc;
- Flange and insulating gasket for fixing at boiler;
- Three-phase power supply;
- Direct fan motor start;
- Burner terminal strip with terminal dedicated for 3ph/1ph power supply and for the connections to thermostats/boiler in-out signals;
- Burner electrical panel with: display with lock-out reset button, white led for power supply presence, green illuminated switch ON/OFF, green led for flame alight;
- Safety air pressure switch to stop the burner in lock-out in case of failed or anomalous fan operation;
- Gas train completely assembled and tested; complete of: working valve class A - safety valve class A - minimum gas pressure switch - gas valve proving pressure switch - filter;
- UV probe for flame detection;
- Pilot flame;
- IP 40 electric protection level;
- Spherical gas valve servo-controlled; progressive start and free way passage with total opening;
- Servomotor for air shutter and for the spherical gas valve;
- Moving shutter with total closure when idle in order to reduce at the least energy losses related to boiler cooling down;
- Easy extraction of combustion head without get off the burners by bolier;
- Maximum gas pressure switch to stop the burner in lock-out in case of the gas pressure is higher then the set point value;
- Set up for the additional specific kit that transforms burner operation as modulating i.e. the modulating kit allows to supply any power between the minimun and the maximum value based on instantaneous loading request.

### CONFORMING TO:

- CE rules;
- 2014/30/UE Directive E.M.C.;
- 2014/35/UE Directive L.V.;
- 2006/42/CE - 2006/42/EG - 2006/42/EC Directive M.D.;
- Reference rules: EN676 (gas) - EN746-2 (industrial thermoprocessing equipment).

### STANDARD EQUIPMENT

- Isomart gasket;
- Flange with insulating gasket;
- Burner nameplate;
- Warranty;
- Instruction handbook for installation, use and maintenance.



# GAS BURNERS LOW NOX TWO STAGES PROGRESSIVE OR MODULATING WITH ELECTRONIC CONTROL BOX



SK073049\_B\_en

## OPTIONAL

- Power modulating kits for temperatures;
- Power modulating kits for pressures;
- Kit for input 4-20mA / 0-10Vdc;
- Temperature probe 0°C-400°C (PT 100 a 0° C);
- Temperature probe 0°C-350°C (J probe);
- Temperature probe 0°C-1200°C (K probe);
- Pressure probe 0-3 bar, 0-6 bar, 0-16 bar, 0-20 bar, 0-30 bar;
- Sensors and system for O<sub>2</sub> control (is suggest to add the VSD);
- Sensors and system for CO control (is suggest to add the VSD);
- Sensors and system for O<sub>2</sub>-CO control (is suggest to add the VSD);
- Modules for field BUS (modbus - profibus - profinet);
- Noise protection;
- Antivibration couplings;
- Handle gas taps.